

**COMPLEX
SOLUTIONS
MADE
SIMPLE.**



DSEEXTRA®

DSE124 CAN extender operator manual

Document Number 057-116

Author : Anthony Manton



Deep Sea Electronics Plc
Highfield House
Hunmanby
North Yorkshire
YO14 0PH
ENGLAND

Sales Tel: +44 (0) 1723 890099
Sales Fax: +44 (0) 1723 893303

E-mail: sales@deepseapl.com
Website: www.deepseapl.com

DSE Model 124 CAN Extender Operators Manual

© Deep Sea Electronics Plc

All rights reserved. No part of this publication may be reproduced in any material form (including photocopying or storing in any medium by electronic means or other) without the written permission of the copyright holder except in accordance with the provisions of the Copyright, Designs and Patents Act 1988.

Applications for the copyright holder's written permission to reproduce any part of this publication should be addressed to Deep Sea Electronics Plc at the address above.

The DSE logo and the names DSEUltra, DSEControl, DSEPower, DSEExtra, DSEMarine and DSENet are UK registered trademarks of Deep Sea Electronics PLC.

Any reference to trademarked product names used within this publication is owned by their respective companies.

Deep Sea Electronics Plc reserves the right to change the contents of this document without prior notice.

Amendments since last publication

| Amd. No. | Comments |
|----------|---------------|
| Issue 1 | First release |
| | |
| | |

Clarification of notation used within this publication.



| | |
|--|---|
|  NOTE: | Highlights an essential element of a procedure to ensure correctness. |
|  CAUTION! | Indicates a procedure or practice, which, if not strictly observed, could result in damage or destruction of equipment. |
|  WARNING! | Indicates a procedure or practice, which could result in injury to personnel or loss of life if not followed correctly. |

TABLE OF CONTENTS

| Section | Page |
|--|-------------|
| 1 BIBLIOGRAPHY..... | 4 |
| 1.1 INSTALLATION INSTRUCTIONS..... | 4 |
| 1.2 MANUALS..... | 4 |
| 2 INTRODUCTION..... | 4 |
| 3 SPECIFICATIONS..... | 5 |
| 3.1 PART NUMBERING..... | 5 |
| 3.1 POWER SUPPLY REQUIREMENTS..... | 6 |
| 3.2 TERMINAL SPECIFICATION..... | 6 |
| 3.3 INPUTS..... | 6 |
| 3.3.1 DIGITAL INPUT..... | 6 |
| 3.4 COMMUNICATION PORTS..... | 6 |
| 3.4.1 COPPER PORTS..... | 6 |
| 3.4.2 FIBRE OPTIC PORT..... | 8 |
| 3.5 DIMENSIONS AND MOUNTING..... | 9 |
| 3.5.1 DIMENSIONS..... | 9 |
| 3.5.2 WEIGHT..... | 9 |
| 3.6 APPLICABLE STANDARDS..... | 9 |
| 4 INSTALLATION..... | 10 |
| 4.1 TERMINAL DESCRIPTION..... | 10 |
| 4.1.1 SCREW TERMINALS (DSE124-01 AND DSE124-02)..... | 10 |
| 4.1.2 ST BAYONET OPTICAL CONNECTIONS (DSE124-01 ONLY)..... | 11 |
| 5 TYPICAL CONNECTION DIAGRAM..... | 12 |
| 6 TYPICAL SYSTEM SCHEMATICS..... | 13 |
| 6.1 COPPER CABLE EXPANSION..... | 13 |
| 6.1.1 EXTENDING THE DSE LOAD SHARE MULTISSET COMMUNICATIONS (MSC) LINK13 | |
| 6.1.2 EXTENDING THE DSE CAN LINK TO AN ENGINE ECU..... | 14 |
| 6.2 FIBRE OPTIC EXPANSION..... | 15 |
| 6.2.1 EXTENDING THE DSE LOAD SHARE MULTISSET COMMUNICATIONS (MSC) LINK15 | |
| 6.2.2 EXTENDING THE DSE CAN LINK TO AN ENGINE ECU..... | 16 |
| 6.3 FIBRE OPTIC EXPANSION WITH 'T' JUNCTION TO COPPER..... | 17 |
| 6.4 COMPLEX EXAMPLE WITH OPTIC FIBRE AND COPPER EXTENSIONS..... | 18 |
| 7 BUS TIE BREAKER..... | 19 |
| 7.1 BREAKING A COPPER MSC LINK..... | 19 |
| 7.2 BREAKING A FIBRE MSC LINK..... | 20 |
| 8 CONTROLS AND INDICATIONS..... | 21 |
| 8.1 CONFIGURATION SWITCH..... | 21 |
| 8.2 STATUS LEDS..... | 21 |
| 9 MAINTENANCE, SPARES, REPAIR AND SERVICING..... | 22 |
| 10 WARRANTY..... | 22 |
| 11 DISPOSAL..... | 22 |
| 11.1 WEEE (WASTE ELECTRICAL AND ELECTRONIC EQUIPMENT)..... | 22 |
| 11.2 ROHS (RESTRICTION OF HAZARDOUS SUBSTANCES)..... | 22 |

1 BIBLIOGRAPHY

The following DSE publications are available to assist with usage of the DSE124 CAN extender module.

1.1 INSTALLATION INSTRUCTIONS

| DSE PART | DESCRIPTION |
|----------|--|
| 053-068 | DSE124 installation instructions. - Also supplied in the packing box with the DSE124 |

1.2 MANUALS

| DSE PART | DESCRIPTION |
|----------|--|
| 057-004 | Electronic Engines and DSE wiring. - Details connections of the CAN link to the engine ECU |
| 057-047 | Load Share Design and Commissioning Guide |

2 INTRODUCTION

This document details the installation and operation requirements of the DSE124, part of the DSEExtra® range of products.

The manual forms part of the product and should be kept for the entire life of the product. If the product is passed or supplied to another party, ensure that this document is passed to them for reference purposes.

This is not a *controlled document*. You will not be automatically informed of updates. Any future updates of this document will be included on the DSE website at www.deepseapl.com

DSE124 is a CAN bus extender to:

- Extend the MSC bus of DSE Synchronising and Load Sharing controllers beyond the maximum 250m normally specified.
- Extend the CAN connection from DSE controller to Engine ECU beyond the distance normally specified by the engine manufacturer.

The DSE124 divides the CAN connection into segments. This has benefits beyond the raising of the maximum distance of the connection:

- It is possible to create branches or T-Junctions in the MSC link, allowing more flexibility around the normally simple linear structure of the CAN specification.
- It increases the system reliability. The *MSC Alarm* of the DSE load share controller can be configured so that a broken segment does not cause other segments to fail. Using the *Status LEDs* on the DSE124 module allows the failed segment to be easily detected.

A robust plastic case designed for chassis or DIN rail mounting houses the module. Connections are via screw terminals and ST type bayonet connectors for the fibre optic interface.

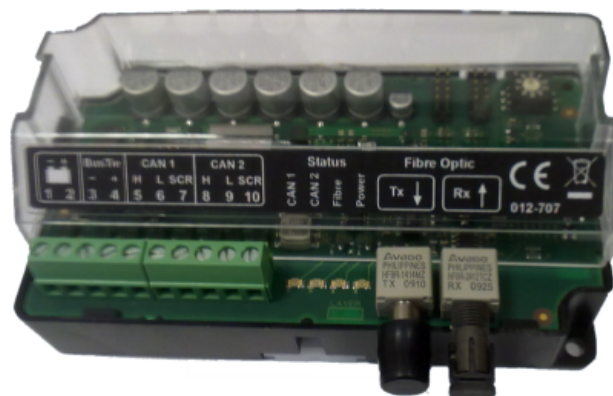

3 SPECIFICATIONS

3.1 PART NUMBERING

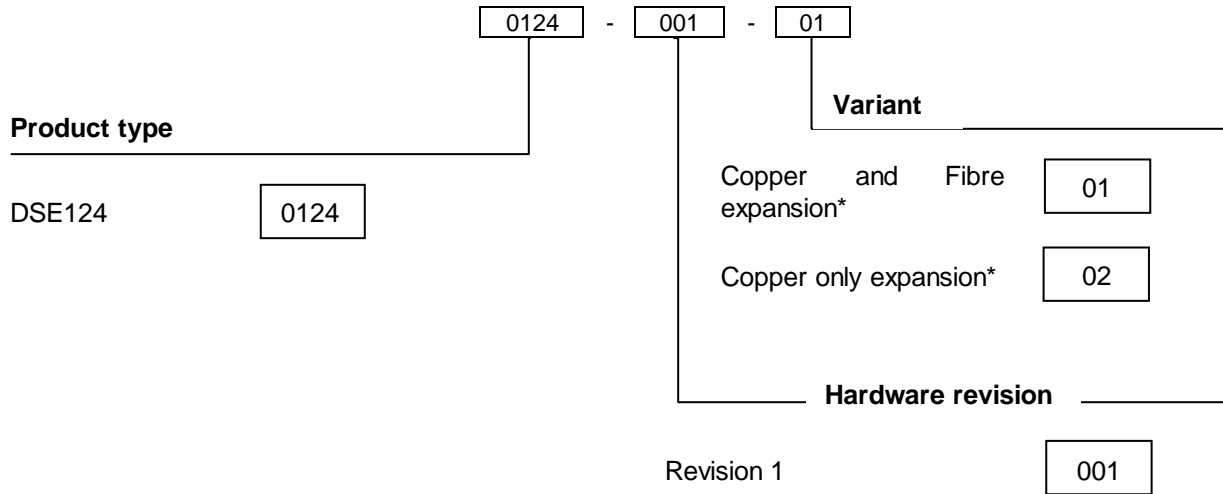

NOTE:- DSE124-01 is EN60825-1 classification 'Class 1 LED Device'

NOTE*:-

Model DSE124-01 Includes interfaces for both copper and fibre connections and is used to extend the connection using either copper or fibre

Model DSE124-02 includes interfaces for copper only

3.1 POWER SUPPLY REQUIREMENTS

| | |
|--|---|
| Minimum supply voltage | 8V continuous |
| Cranking dropouts | Able to survive 0V for 50mS providing the supply was at least 10V before the dropout and recovers to 5V afterwards. |
| Maximum supply voltage | 35V continuous (60V protection) |
| Reverse polarity protection | -35V continuous |
| Maximum operating current (Digital input grounded, passing MSC protocol at 75% bus capacity, Fibre port fitted) | 191mA at 12V, 99mA at 24V |
| Nominal standby current (Input not active, no activity on copper or fibre ports) | 147mA at 12V, 76mA at 2 |

3.2 TERMINAL SPECIFICATION

| | |
|-----------------|--|
| Connection type | Screw terminal, rising clamp, no internal spring |
| Min cable size | 0.5mm ² (AWG 24) |
| Max cable size | 2.5mm ² (AWG 10) |

3.3 INPUTS

3.3.1 DIGITAL INPUT

Dedicated to bus tie auxiliary in MSC mode, not used in J1939 mode

| | |
|-------------------------|--|
| Number | 1 |
| Arrangement | Contact between terminal and ground |
| Low level threshold | 3.2V minimum |
| High level threshold | 8.1V maximum |
| Maximum input voltage | +60V DC with respect to supply positive terminal |
| Minimum input voltage | -24V DC with respect to supply negative terminal |
| Contact wetting current | 7mA ±1mA |
| Open circuit voltage | 12V ±1V |

3.4 COMMUNICATION PORTS

3.4.1 COPPER PORTS

| | |
|---|---|
| Recommended Cable Type | Belden 9841 (DSE Part Number 016-030) |
| Interface type | PCA82C251 or compatible IC |
| Isolation | Galvanic isolation to 50V |
| Bit rate | 250k bits/s |
| Tq(time quantisation) | 250nS |
| SYNC_SEG (synchronisation segment) | 1 Tq |
| TSEG1 (equivalent to PROP_SEG+PHASE_SEG1) | 13 Tq |
| TSEG2 (equivalent to PHASE_SEG2) | 2 Tq |
| Termination | 120 Ohm / 0.4W must be fitted externally to the ends of the copper link as per CAN specification. |
| Maximum cable length | 250m when using recommended cable |
| Topology | Bus with no spurs |
| Max copper segments per system | 8 (eight) |
| Protocol | Compliant with CAN 2.0B |
| Identifiers | 11 bit in MSC mode or 29 bit in J1939 mode |

| | |
|----------------|---|
| Message format | Compatible with DSE MSC bus in MSC mode and J1939 in J1939 mode |
|----------------|---|

3.4.2 FIBRE OPTIC PORT

 **WARNING:-** 200µm cable must not be connected as this could potentially cause injury by increasing the power of the fibre output to 'Class 3A LED'.

 **NOTE:-** Fibre optic specifications are applicable only to model DSE124-01

 **NOTE:-** DSE124-01 is EN60825-1 classification 'Class 1 LED Device'

| | |
|-------------------------------|--|
| Connector type | ST type bayonet connectors |
| Recommended cable type | OM1 glass fibre cable (62/125µm) to ISO/IEC 11801. |
| Optical power budget | 8dB for OM1 fibre. |
| Other cable types | See note below. |
| Number of fibres | Two, one for transmit and one for receive. |
| Isolation | Inherent to fibre optic cable. |
| Bit rate | 1562500 bits/s |
| Maximum cable length | 2000m when using recommended cable. |
| Max fibre segments per system | 2 (two) |
| Topology | 1 to 1 connection between two modules. |
| Protocol | Proprietary. |
| Safety | EN60825-1 classification 'Class 1 LED Device' |

 **NOTE:-** OM 1 fibre is specified to have an attenuation of no more than 3.5db/km therefore a 2km fibre will have an attenuation of no more than 7dB.

The attenuation of a pair of terminations, i.e. both ends of a single fibre added together, is 0.3dB to 0.5dB, the actual measured figure should be quoted on the paperwork supplied with a pre-terminated cable assembly.

Therefore a 2km pre-terminated cable assembly will have an attenuation of no more than $3.5 \times 2 + 0.5 = 7.5\text{dB}$ which leaves 0.5dB from the 8dB optical power budget, sufficient for the addition of a coupling in the middle of the cable assembly should it be required.

Alternatively, two cable assemblies having a total length not exceeding 2km can be coupled together providing both have termination attenuations of no more than 0.5dB.

OM2 and OM3 cables have **not** been tested by DSE. (DSE recommend only OM1 cable).

Theoretically an 800m OM2 fibre can be used provided that the couplings have an attenuation of no more than 0.5dB in total.

3.5 DIMENSIONS AND MOUNTING

3.5.1 DIMENSIONS

| | |
|----------------|---|
| Overall size | 133.9mm x 76.4mm x 48.9mm (5.3" x 3.0" x 1.9"). Fibre optic connections protrude 15mm from the case. Allow sufficient further space for the fibre cable to be routed. |
| Mounting type | DIN rail or direct to chassis. |
| DIN rail type | EN 50022 35mm type only |
| Mounting holes | M4 clearance, centres at 122.5mm x 64.5mm (1/8" clearance, centres at 4.8" x 2.5") |

3.5.2 WEIGHT

0.2kg (200g)

3.6 APPLICABLE STANDARDS

| | |
|---|--|
| BS 4884-1 | This document conforms to BS4884-1 1992 Specification for presentation of essential information. |
| BS 4884-2 | This document conforms to BS4884-2 1993 Guide to content |
| BS 4884-3 | This document conforms to BS4884-3 1993 Guide to presentation |
| BS EN 60068-2-1 (Minimum temperature) | -30°C (-22°F) |
| BS EN 60068-2-2 (Maximum temperature) | +70°C (158°F) |
| BS EN 60950 | Safety of information technology equipment, including electrical business equipment |
| BS EN 61000-6-2 | EMC Generic Immunity Standard (Industrial) |
| BS EN 61000-6-4 | EMC Generic Emission Standard (Industrial) |
| EN60825-1 | DSE124-01 is EN60825-1 classification 'Class 1 LED Device' |

In line with our policy of continual development, Deep Sea Electronics, reserve the right to change specification without notice.

4 INSTALLATION

The DSE60xx Series module is designed to be mounted on the panel DIN rail or bolted to the chassis. For dimension and mounting details, see the section entitled *Specification, Dimension and mounting* elsewhere in this document.

4.1 TERMINAL DESCRIPTION

4.1.1 SCREW TERMINALS (DSE124-01 AND DSE124-02)

| PIN No | DESCRIPTION | NOTES |
|--------|--|--|
| 1 | Plant supply negative | |
| 2 | Plant supply positive | (Recommended Maximum Fuse 2A anti-surge) |
| 3 | Bus tie common (connected to plant supply negative) | |
| 4 | Bus tie input | Connect to Plant Supply Negative from terminal 3 when bus tie breaker is open/closed (configurable by selector switch) |
| 5 | Copper CAN port 1 H | Recommended cable type Belden 9841 |
| 6 | Copper CAN port 1 L | |
| 7 | Copper CAN port 1 Screen | |
| 8 | Copper CAN port 2 H | Recommended cable type Belden 9841 |
| 9 | Copper CAN port 2 L | |
| 10 | Copper CAN port 2 Screen | |

NOTE:- Screened 120Ω impedance cable specified for use with CAN must be used for the CAN link and the Multiset comms link.
DSE stock and supply Belden cable 9841 which is a high quality 120Ω impedance cable suitable for CAN use (DSE part number 016-030)

NOTE:- Ensure 120Ω termination resistor is correctly fitted at both ends of the copper cable as per CAN specification.

4.1.2 ST BAYONET OPTICAL CONNECTIONS (DSE124-01 ONLY)



WARNING:- 200µm cable must not be connected as this could potentially cause injury by increasing the power of the fibre output to 'Class 3A LED'.



NOTE:- Fibre optic specifications are applicable only to model DSE124-01



NOTE:- DSE124-01 is EN60825-1 classification 'Class 1 LED Device'

| | | |
|-------|----------------------|---|
| FIBRE | Fibre optic Transmit | OM1 glass fibre cable (62/125µm) to ISO/IEC 11801. |
| FIBRE | Fibre optic Receive | |



NOTE:- Connect Tx (transmit) from one DSE124 to the Rx (receive) connection of the other.

5 TYPICAL CONNECTION DIAGRAM

WARNING:- 200µm cable must not be connected as this could potentially cause injury by increasing the power of the fibre output to 'Class 3A LED'.

NOTE:- Fibre optic connectors are applicable only to model DSE124-01

NOTE:- DSE124-01 is EN60825-1 classification 'Class 1 LED Device'

NOTE:- Ensure 120Ω termination resistor is correctly fitted at both ends of the copper cable as per CAN specification.

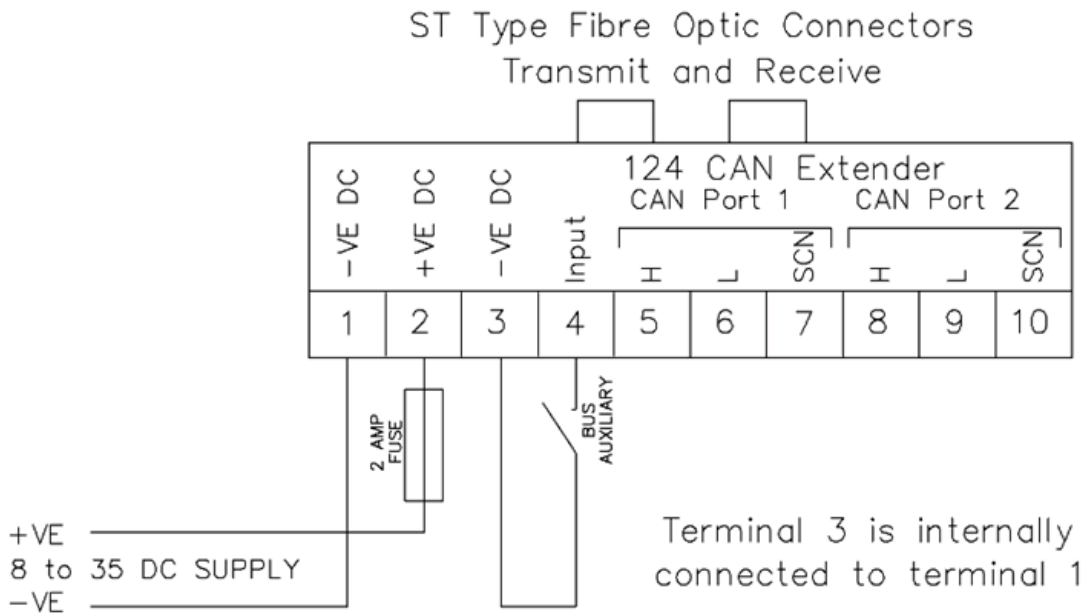

Bus auxiliary contact (terminal 4) is only required where a bus tie breaker is fitted.

6 TYPICAL SYSTEM SCHEMATICS

6.1 COPPER CABLE EXPANSION

This facility is available with either DSE124-01 or DSE124-02.

A Maximum of 8 (eight) copper expansions, max 250m each, are able to be fitted in each installation.

The following examples are representative of real life applications and in no way form an exhaustive list of possible uses for the DSE124 module.

6.1.1 EXTENDING THE DSE LOAD SHARE MULTISSET COMMUNICATIONS (MSC) LINK

NOTE:- Ensure 120Ω termination resistor is correctly fitted at both ends of the copper cable as per CAN specification.

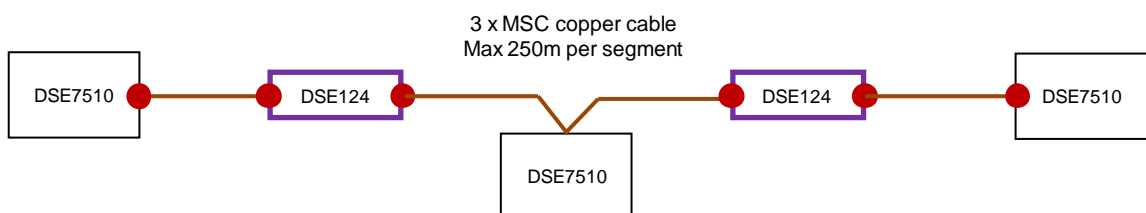
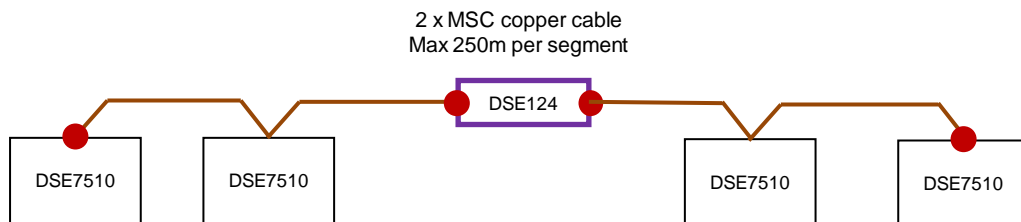
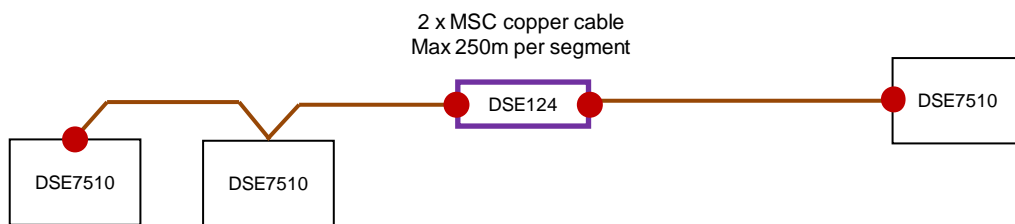
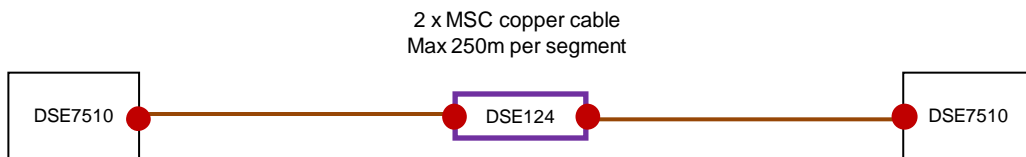

| Legend | Description |
|--------|--|
| ● | 120Ω Termination resistor fitted from CAN H to CAN L as per CAN specification. Must be fitted to the 'ends' of COPPER CAN cables. |
| — | MSC copper cable. Max 250m when using Belden 9841 cable. (DSE part number 016-030). Maximum 8 (eight) copper segments in any one system. |



6.1.2 EXTENDING THE DSE CAN LINK TO AN ENGINE ECU

This facility is available on all DSE controllers with CAN interface.

NOTE:- Ensure 120Ω termination resistor is correctly fitted at both ends of the copper cable as per CAN specification.
 This termination resistor is internally fitted to the DSE engine controller.
 Check with engine ECU manufacturer if the resistor is required external to the ECU or if it is fitted internally.

| Legend | Description |
|---|--|
|  | 120Ω Termination resistor fitted from CAN H to CAN L as per CAN specification. Must be fitted to the 'ends' of COPPER CAN cables. |
|  | MSC copper cable. Max 250m when using Belden 9841 cable. (DSE part number 016-030). Maximum 8 (eight) copper segments in any one system. |

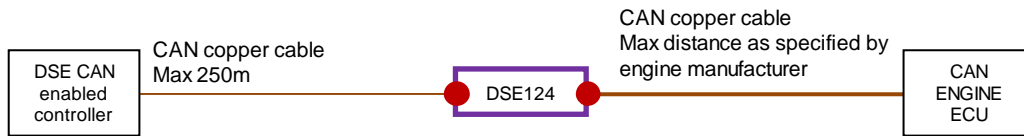



6.2 FIBRE OPTIC EXPANSION

This facility is only available with DSE124-01

A Maximum of 8 (eight) copper expansions, max 250m each, are able to be fitted in each installation.

A Maximum of 2 (two) fibre expansions, max 2000m each, are able to be fitted in each installation.

6.2.1 EXTENDING THE DSE LOAD SHARE MULTISSET COMMUNICATIONS (MSC) LINK

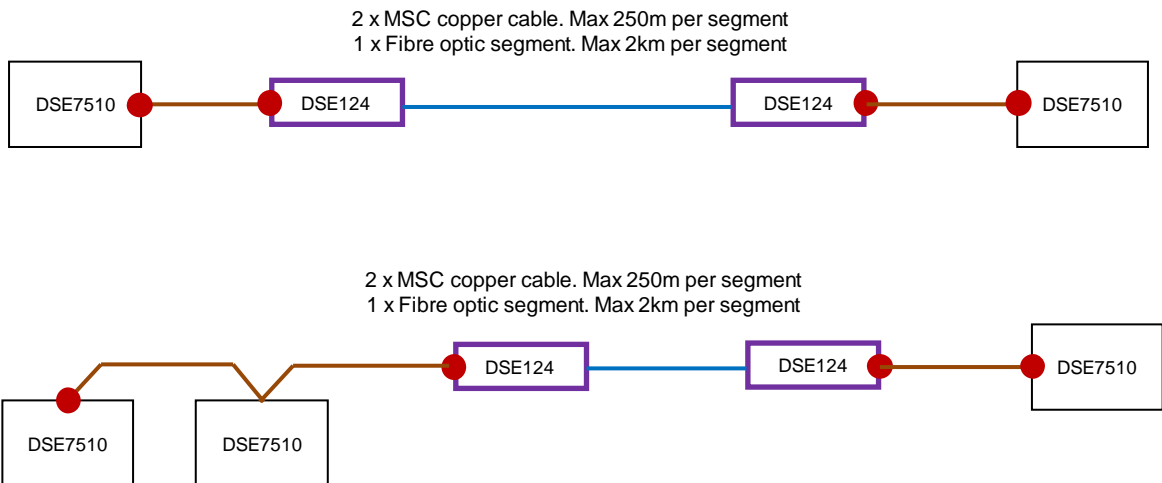

| Legend | Description |
|---|--|
|  | 120Ω Termination resistor fitted from CAN H to CAN L as per CAN specification. Must be fitted to the 'ends' of COPPER CAN cables. |
|  | MSC copper cable. Max 250m when using Belden 9841 cable. (DSE part number 016-030). Maximum 8 (eight) copper segments in any one system. |
|  | Fibre Optic Extension. Max 2km when using OM1 glass fibre cable (62/125µm) to ISO/IEC 11801. Maximum 2 (two) fibre segments in any one system. |

NOTE:- Ensure 120Ω termination resistor is correctly fitted at both ends of the copper cable as per CAN specification.



6.2.2 EXTENDING THE DSE CAN LINK TO AN ENGINE ECU

This facility is only available with DSE124-01
 This facility is available on all DSE controllers with CAN interface.

| Legend | Description |
|---|--|
|  | 120Ω Termination resistor fitted from CAN H to CAN L as per CAN specification. Must be fitted to the 'ends' of COPPER CAN cables. |
|  | MSC copper cable. Max 250m when using Belden 9841 cable. (DSE part number 016-030). Maximum 8 (eight) copper segments in any one system. |
|  | Fibre Optic Extension. Max 2km when using OM1 glass fibre cable (62/125µm) to ISO/IEC 11801. Maximum 2 (two) fibre segments in any one system. |

NOTE:- Ensure 120Ω termination resistor is correctly fitted at both ends of the copper cable as per CAN specification.
 This termination resistor is internally fitted to the DSE engine controller.
 Check with engine ECU manufacturer if the resistor is required external to the ECU or if it is fitted internally.



6.3 FIBRE OPTIC EXPANSION WITH 'T' JUNCTION TO COPPER

This facility is only available with DSE124-01 when used as an extension to the DSE Load Share MultiSet Communications (MSC) Link.

AS DSE124-01 has both copper and fibre interfaces fitted, it is possible to use the device as a 'T' junction. CAN1 and CAN2 are able to be run as individual copper MSC connections, using the fibre interface to connect to another copper cable.

| Legend | Description |
|--------|--|
| ● | 120Ω Termination resistor fitted from CAN H to CAN L as per CAN specification. Must be fitted to the 'ends' of COPPER CAN cables. |
| — | MSC copper cable. Max 250m when using Belden 9841 cable. (DSE part number 016-030). Maximum 8 (eight) copper segments in any one system. |
| — | Fibre Optic Extension. Max 2km when using OM1 glass fibre cable (62/125µm) to ISO/IEC 11801. Maximum 2 (two) fibre segments in any one system. |

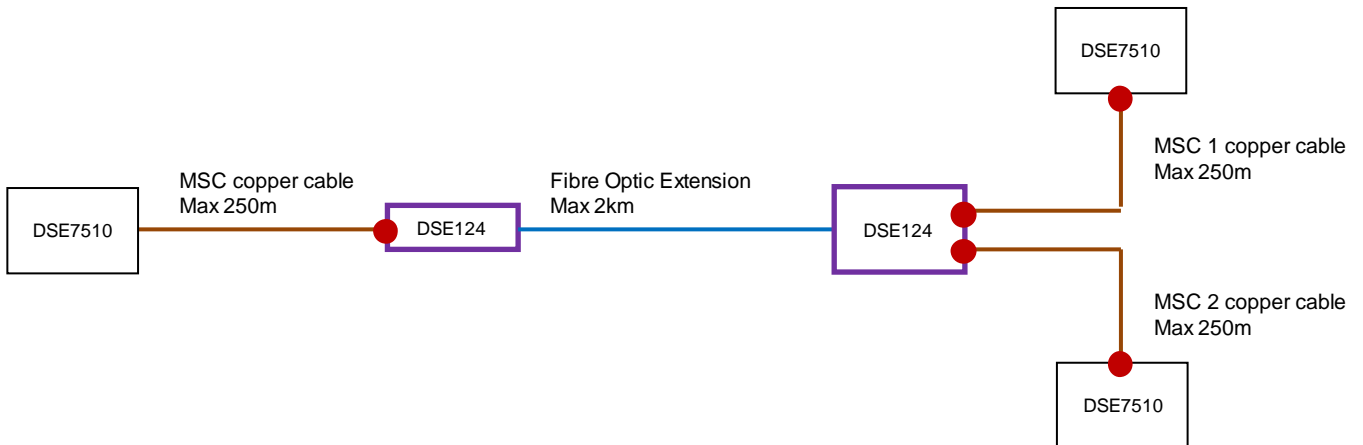

NOTE:- Ensure 120Ω termination resistor is correctly fitted at both ends of the copper cable as per CAN specification.



6.4 COMPLEX EXAMPLE WITH OPTIC FIBRE AND COPPER EXTENSIONS

This facility is only available with DSE124-01

NOTE:- Do not attempt to create a 'loop back' or 'ring' of connections. This WILL NOT work!

| Legend | Description |
|---|--|
|  | 120Ω Termination resistor fitted from CAN H to CAN L as per CAN specification. Must be fitted to the 'ends' of COPPER CAN cables. |
|  | MSC copper cable. Max 250m when using Belden 9841 cable. (DSE part number 016-030). Maximum 8 (eight) copper segments in any one system. |
|  | Fibre Optic Extension. Max 2km when using OM1 glass fibre cable (62/125µm) to ISO/IEC 11801. Maximum 2 (two) fibre segments in any one system. |

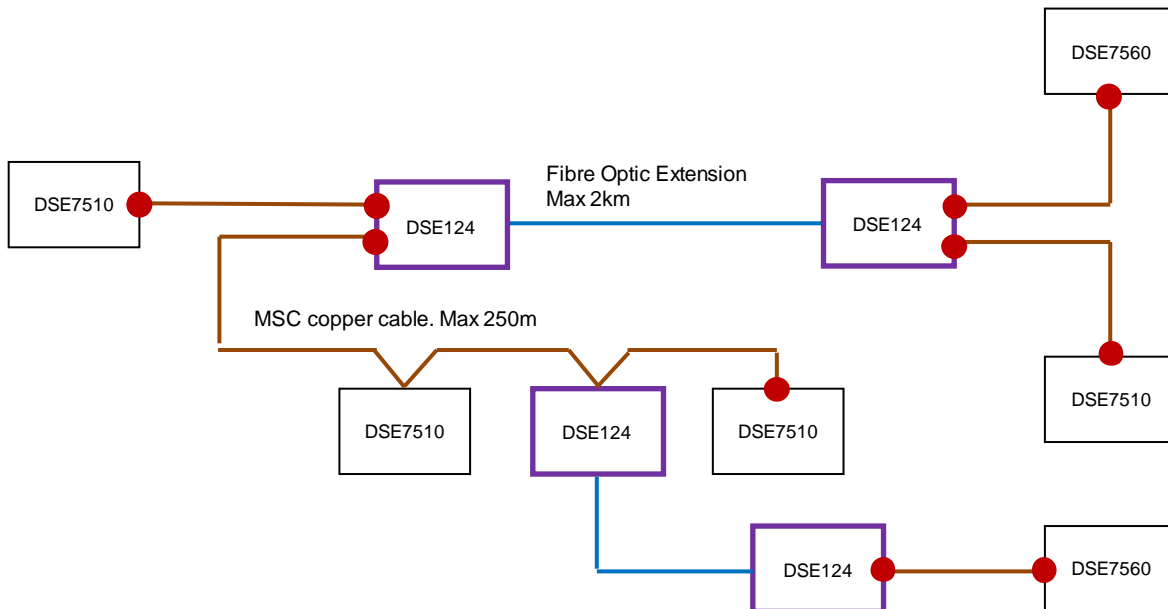

7 BUS TIE BREAKER

A digital input is provided on the DSE124 for use where the MSC link of a load share system requires 'breaking' due to the positioning of a 'bus tie breaker'.

NOTE:- At the time of going to press (Nov '09) no facility exists to 'actively' synchronise the two sides of a bus tie breaker. An external check sync relay must be fitted across the tie breaker to ensure it only closes when the two supplies are in synchronism. The two supplies will be allowed to 'drift' into sync. A DSE controller to actively synchronise and close a bus tie breaker will be available in the first half of 2010.

7.1 BREAKING A COPPER MSC LINK

In the following system, the MSC link must be disabled when the bus tie breaker is opened, and reinstated when the bus tie breaker is closed.

The DSE124 module automatically performs this switching when instructed to do so by the *Bus Tie* digital input fitted to the DSE124.

| Legend | Description |
|--------|--|
| ● | 120Ω Termination resistor fitted from CAN H to CAN L as per CAN specification. Must be fitted to the 'ends' of COPPER CAN cables. |
| — | MSC copper cable. Max 250m when using Belden 9841 cable. (DSE part number 016-030). Maximum 8 (eight) copper segments in any one system. |
| — | Fibre Optic Extension. Max 2km when using OM1 glass fibre cable (62/125µm) to ISO/IEC 11801. Maximum 2 (two) fibre segments in any one system. |

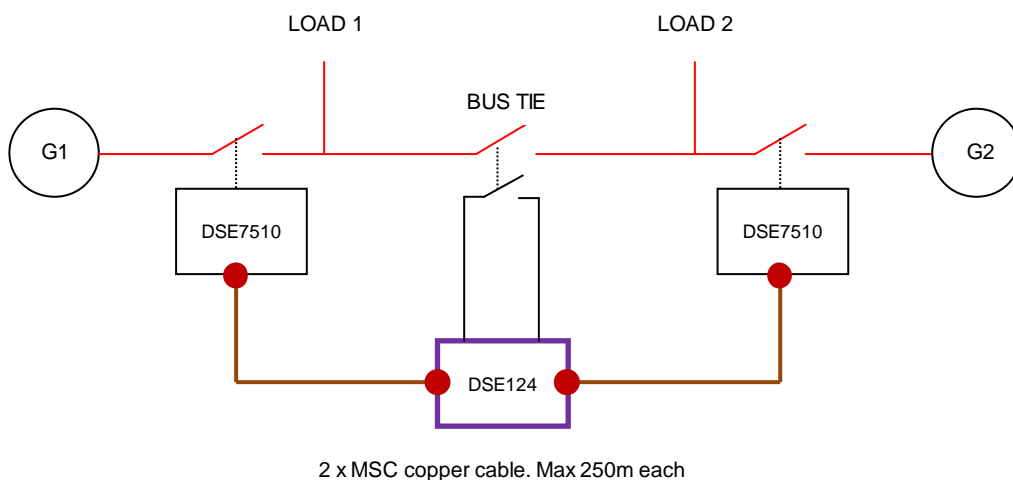



| Configuration switch position | Operating mode | Bus tie location | Digital input polarity |
|-------------------------------|------------------|------------------|---------------------------|
| 1 | MSC bus extender | CAN port 1 | Closed for bus tie closed |
| 2 | MSC bus extender | CAN port 1 | Open for bus tie closed |

For complete listing of possible switch positions, see the section entitled Controls and Indications.

7.2 BREAKING A FIBRE MSC LINK

In the following system, the MSC link must be disabled when the bus tie breaker is opened, and reinstated when the bus tie breaker is closed.

The DSE124 module automatically performs this switching when instructed to do so by the *Bus Tie* digital input fitted to the DSE124.

| Legend | Description |
|---|--|
|  | 120Ω Termination resistor fitted from CAN H to CAN L as per CAN specification. Must be fitted to the 'ends' of COPPER CAN cables. |
|  | MSC copper cable. Max 250m when using Belden 9841 cable. (DSE part number 016-030). Maximum 8 (eight) copper segments in any one system. |
|  | Fibre Optic Extension. Max 2km when using OM1 glass fibre cable (62/125µm) to ISO/IEC 11801. Maximum 2 (two) fibre segments in any one system. |

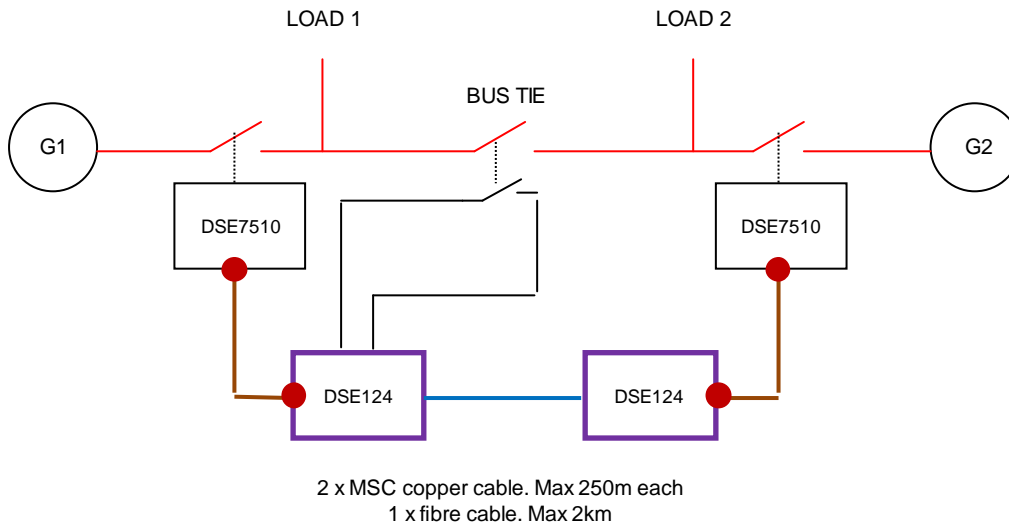

| Configuration switch position | Operating mode | Bus tie location | Digital input polarity |
|-------------------------------|------------------|------------------|---------------------------|
| 3 | MSC bus extender | Fibre port | Closed for bus tie closed |
| 4 | MSC bus extender | Fibre port | Open for bus tie closed |

For complete listing of possible switch positions, see the section entitled Controls and Indications.

8 CONTROLS AND INDICATIONS

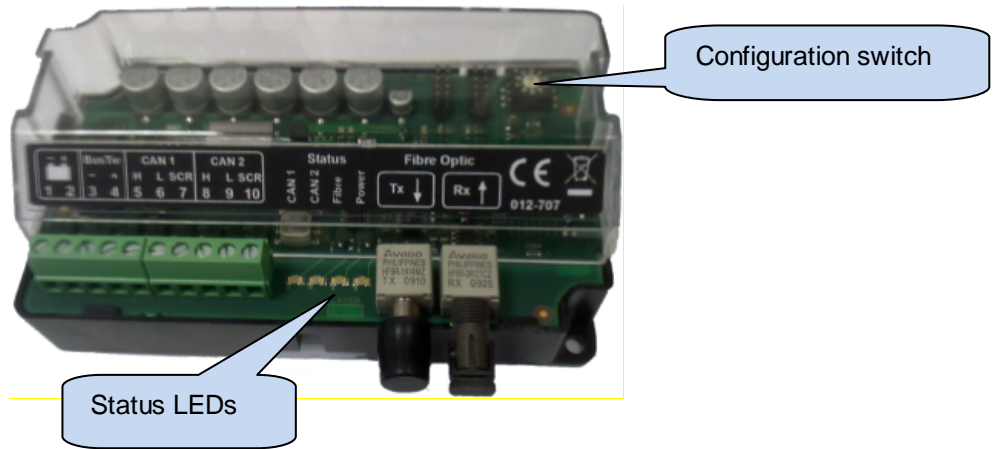

8.1 CONFIGURATION SWITCH

A 10 position rotary switch, accessible by carefully removing the transparent cover, provides configuration as follows:

| Switch position | Operating mode | Bus tie location | Digital input polarity |
|-----------------|--------------------|------------------|---------------------------|
| 0 | MSC bus extender | None | N/A |
| 1 | MSC bus extender | CAN port 1 | Closed for bus tie closed |
| 2 | MSC bus extender | CAN port 1 | Open for bus tie closed |
| 3 | MSC bus extender | Fibre port | Closed for bus tie closed |
| 4 | MSC bus extender | Fibre port | Open for bus tie closed |
| 5 | J1939 bus extender | | |
| 6-9 | Reserved | | |



8.2 STATUS LEADS

Four red LEDs are provided for status indication:

| Name | Description |
|-------|--|
| CAN 1 | Data being received on copper CAN port 1 |
| CAN 2 | Data being received on copper CAN port 2 |
| Fibre | Data being received on Fibre optic port |
| Power | DC Power to module |

Status LEDs

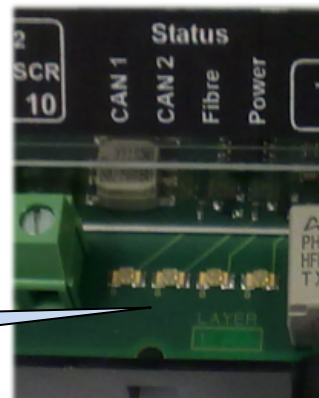

9 MAINTENANCE, SPARES, REPAIR AND SERVICING

The DSE124 is designed to be *Fit and Forget*. As such, there are no user serviceable parts within the controller. In the case of malfunction, you should contact your original equipment supplier (OEM).

10 WARRANTY

DSE provides limited warranty to the equipment purchaser at the point of sale. For full details of any applicable warranty, you are referred to your original equipment supplier (OEM).

11 DISPOSAL

11.1 WEEE (WASTE ELECTRICAL AND ELECTRONIC EQUIPMENT)

Directive 2002/96/EC

If you use electrical and electronic equipment you must store, collect, treat, recycle and dispose of WEEE separately from your other waste.



11.2 ROHS (RESTRICTION OF HAZARDOUS SUBSTANCES)

Directive 2002/95/EC:2006

To remove specified hazardous substances (Lead, Mercury, Hexavalent Chromium, Cadmium, PBB & PBDE's)

Exemption Note: Category 9. (Monitoring & Control Instruments) as defined in Annex 1B of the WEEE directive will be exempt from the RoHS legislation. This was confirmed in the August 2005 UK's Department of Trade and Industry RoHS REGULATIONS Guide (Para 11).

Despite this exemption DSE has been carefully removing all non RoHS compliant components from our supply chain and products.

When this is completed a Lead Free & RoHS compatible manufacturing process will be phased into DSE production.

This is a process that is almost complete and is being phased through different product groups.